

## Wijziging in CAN-bus data verbindingen

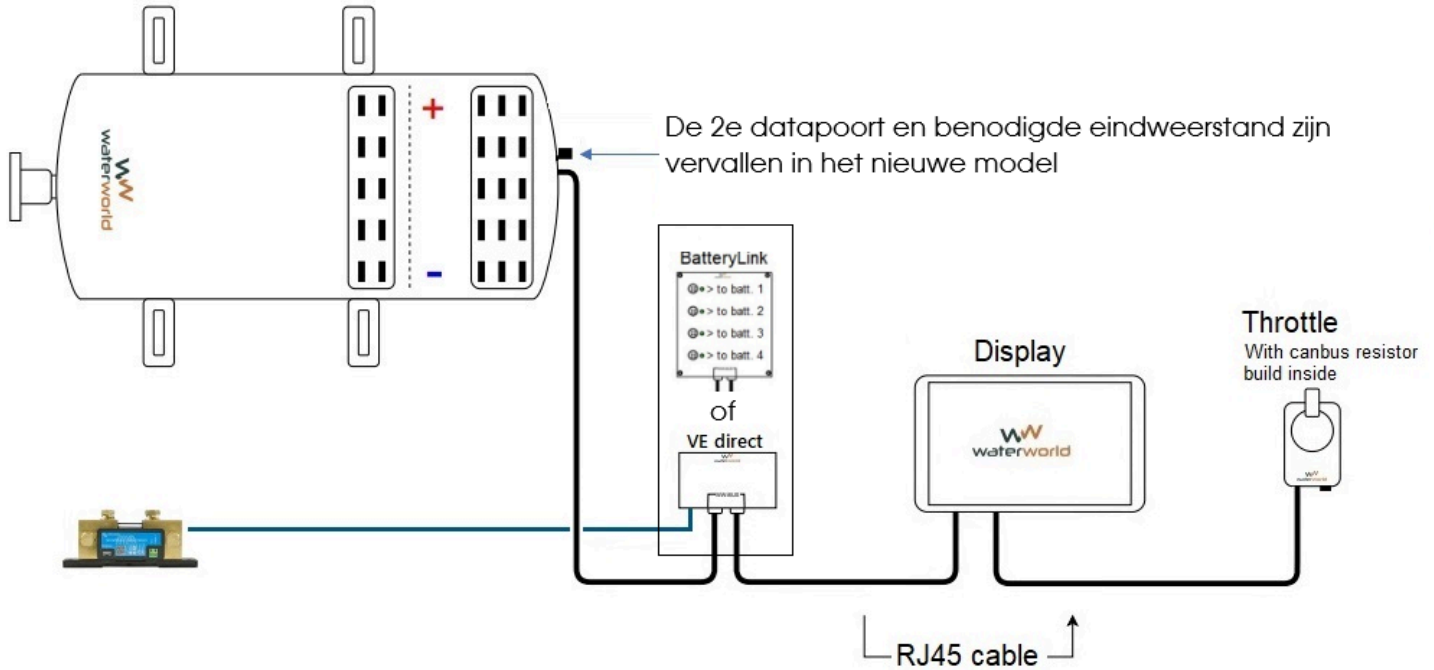

## Wijziging in stroomaansluitingen

