

# Installation Drawing: I06

Version 1.0

Power cable connection



This installation drawing is an addition to the original operating instructions.  
Read operating instructions before wiring.

# TORQUEEDO

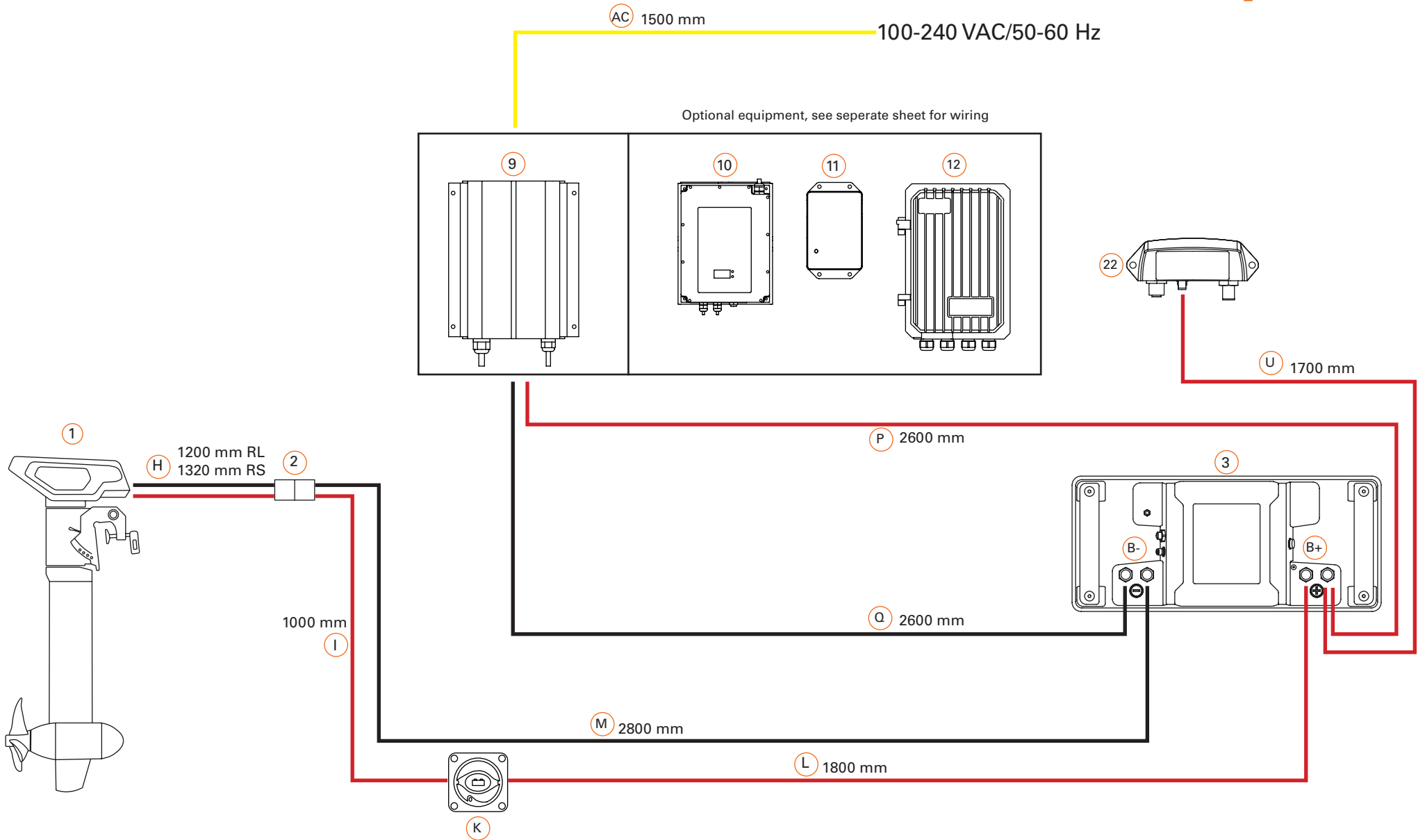

— Positive power cable  
— Negative power cable

— Positive charging cable  
— Negative charging cable

— AC power cable

Power cable connection

# Installation Drawing: I06

Version 1.0

System ground connection



This installation drawing is an addition to the original operating instructions.  
Read operating instructions before wiring.

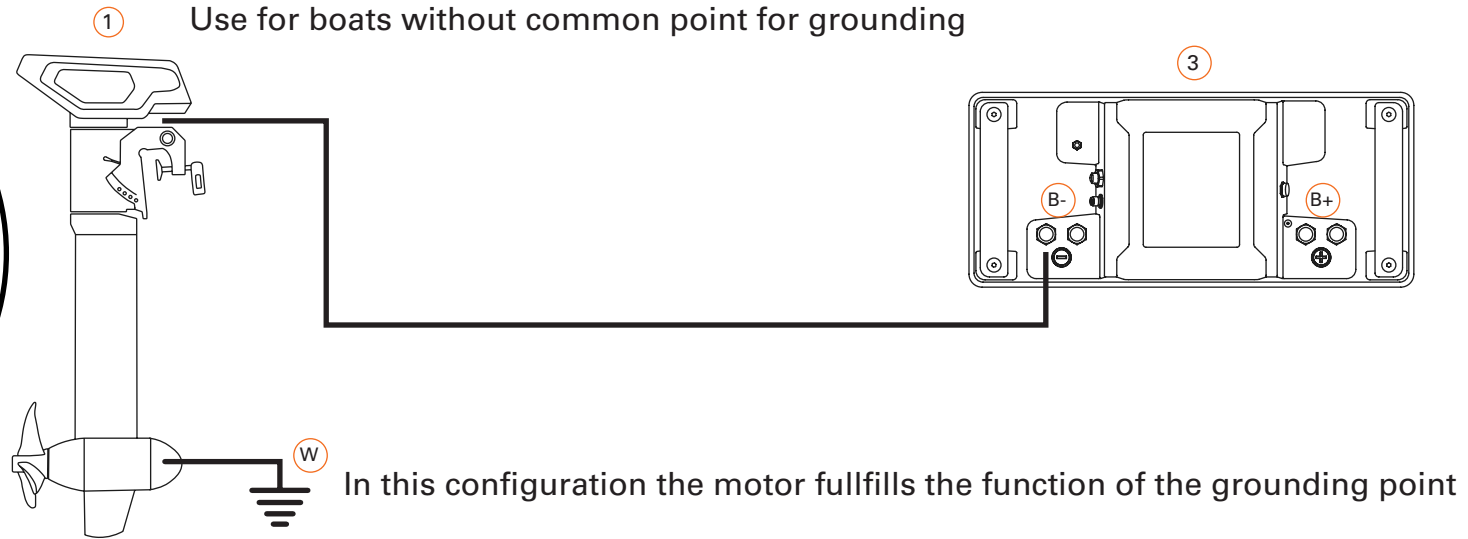
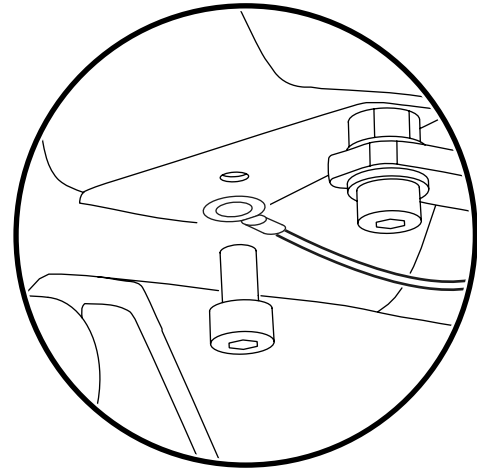

— 25 mm<sup>2</sup> grounding cable

Use for boats with common point for grounding

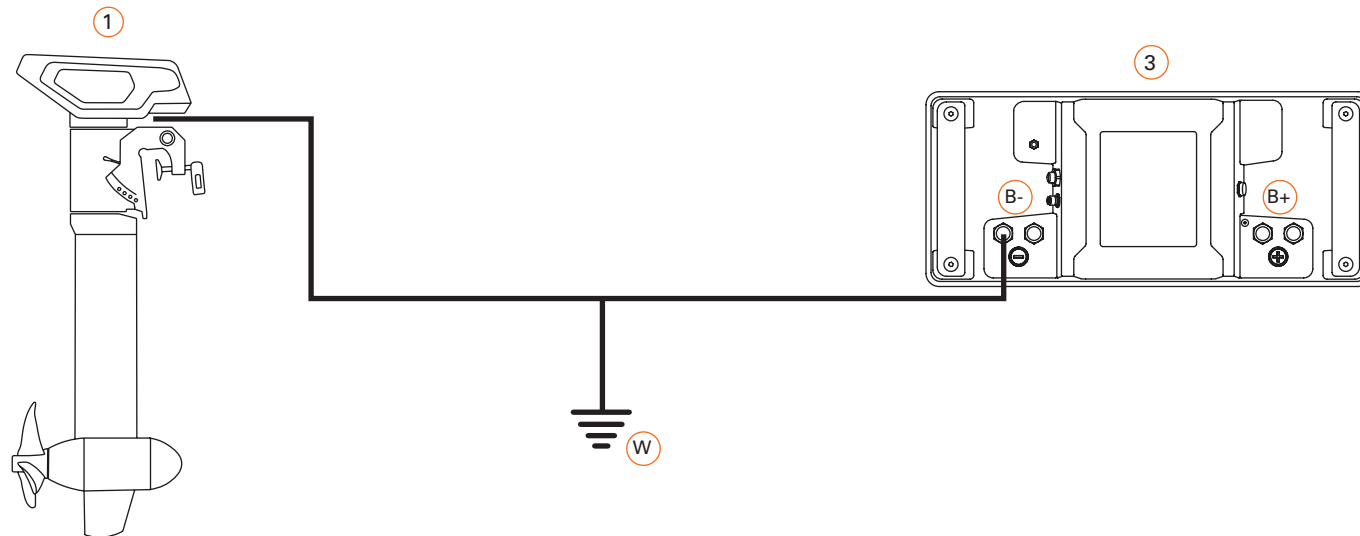
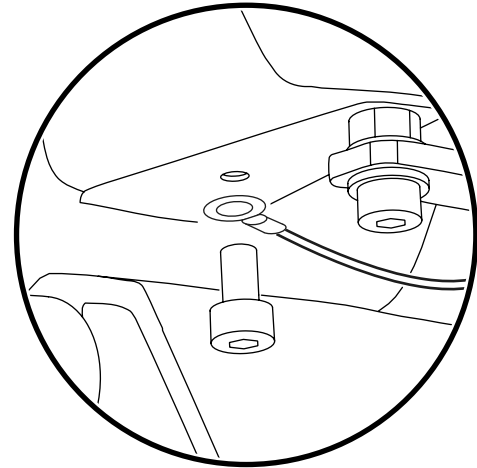

— 25 mm<sup>2</sup> grounding cable

System ground connection

# Installation Drawing: I06

Version 1.0

System ground connection



This installation drawing is an addition to the original operating instructions.  
Read operating instructions before wiring.



In case the charger is permanently installed in the boat, the charger housing or its AC PE and battery minus pole must be connected to the common grounding point.  
The AC connection requires specialist knowledge and may only be carried out by qualified personnel.  
If necessary, have the planning and installation carried out by a specialist.

**NOTE!** To charge the batteries in the boat, a land connection in the boat with galvanic isolator or isolation transformer is required according to applicable national requirements (e.g. DIN EN ISO 13297, ABYC E-11).

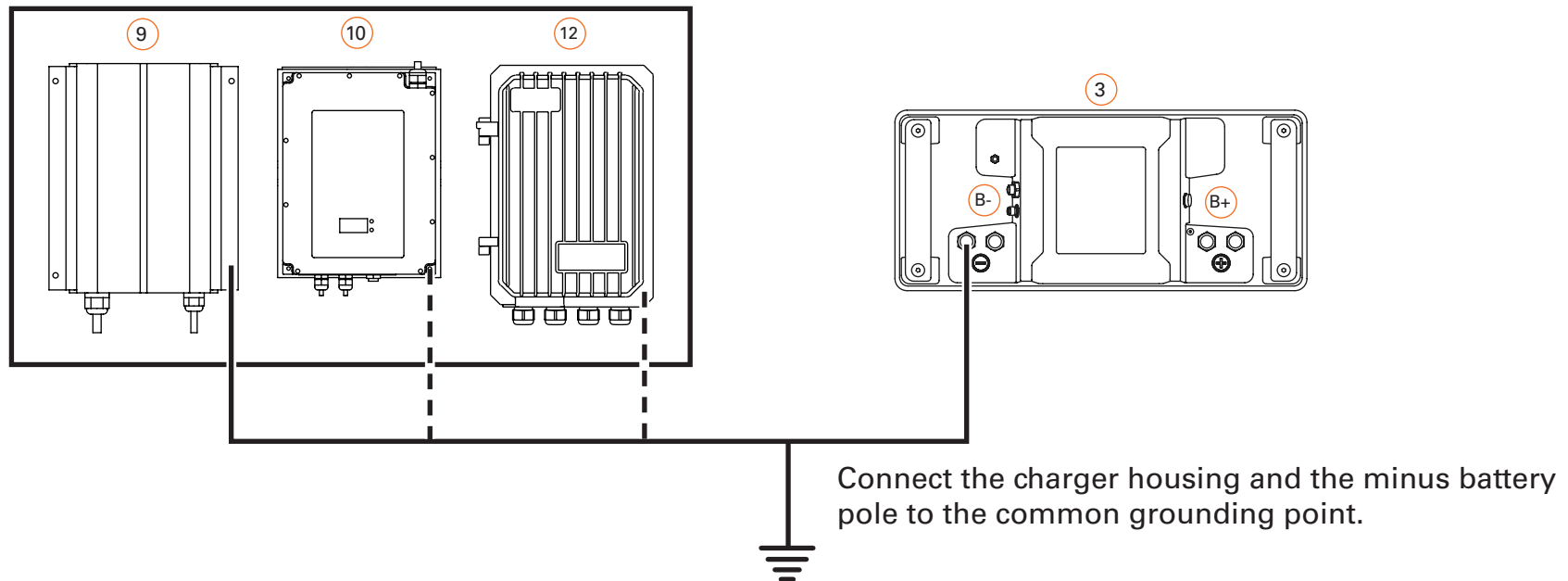

— 25 mm<sup>2</sup> grounding cable

System ground connection

# Installation Drawing: I06

Version 1.0

Data cable connection



This installation drawing is an addition to the original operating instructions.  
Read operating instructions before wiring.

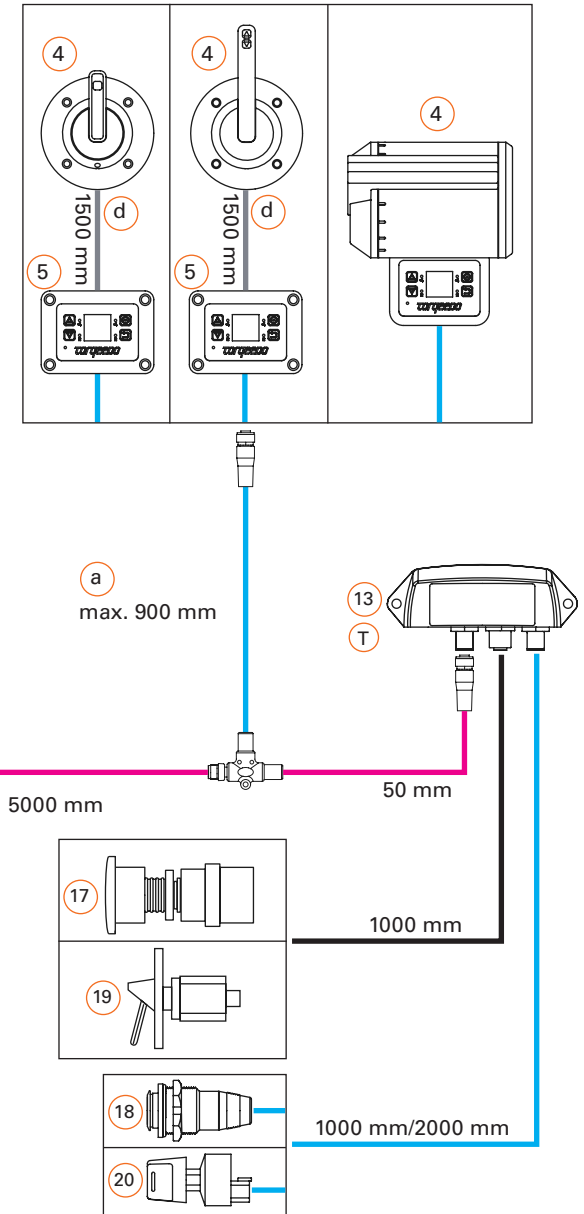
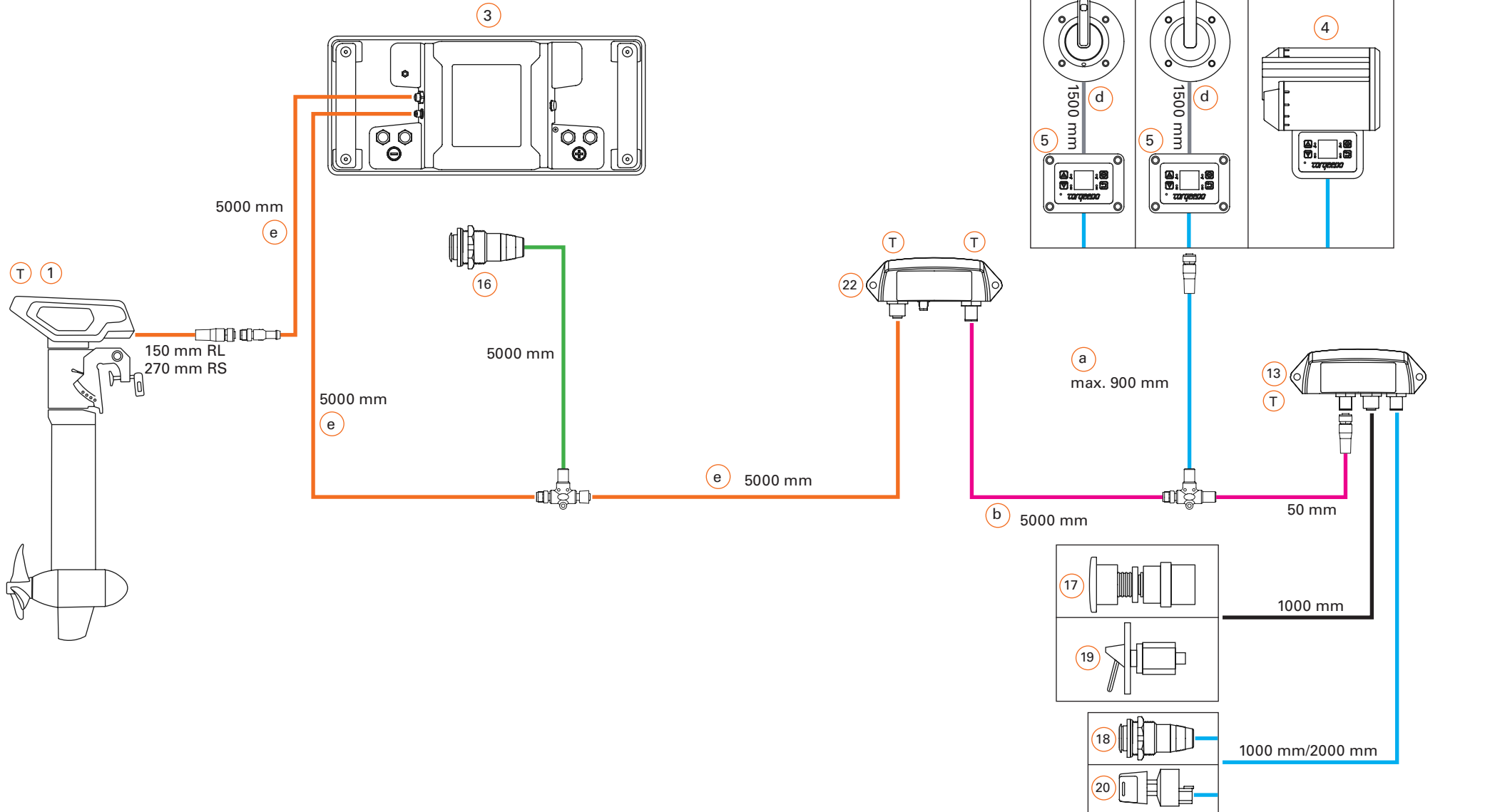

— 8 pin data cable  
— 5 pin data cable

— 4 pin data cable

— Backbone TorqLink, 8 pin data cable  
— Backbone 5 pin data cable

Ⓣ Bus system termination resistor

Data cable connection

# Installation Drawing: I06

Version 1.0

Bill of material/Legend/Information



This installation drawing is an addition to the original operating instructions.  
Read operating instructions before wiring.



Pos.	Item number	Name	Remarks
1	1260-00 1261-00	Cruise 3.0 R	
H, I, K, L, M		Cable set with battery switch	See picture for cable length
2		Power connector	max. 175 A
e		Backbone cable 5-pin	5000 mm
3	2106-00	Power 24-3500	Select TorqLink-Battery in throttle menu!
e		Backbone cable 5-pin	5000 mm
16	2304-00	On/Off Switch Power 24-3500 with cable	5000 mm Use to switch the Power 24-3500 on/off manually, if not in use the Power 24-3500 switches off automatically after 24 hours
W		System ground	min. 25 mm <sup>2</sup> , not included
4	1949-00	Throttle Sidemount Sail	
5		Throttle Display	
22	000-00858	Gateway	
U		Gateway Power cable	1700 mm
b		Backbone TorqLink cable 8-pin	5000 mm
d		Data cable 4-pin	1500 mm
17		Emergency switch with cable	1000 mm
18		On/Off switch with cable	2000 mm
13	000-00876	TorqLink Terminator	Bus termination resistor
a		T-Cable 8-pin	900 mm/50 mm, Do not extend!
4	1950-00	Throttle Sidemount	
5		Throttle Display	
22	000-00858	Gateway	
U		Gateway Power cable	1700 mm
b		Backbone TorqLink cable 8-pin	5000 mm
d		Data cable 4-pin	1500 mm
19		Kill switch with cable	1000 mm
20		Key switch	

Bill of material/Legend/Information

Pos.	Item number	Name	Remarks
g		Cable for key switch 6-Pin to 8-pin	1000 mm
13	000-00876	TorqLink Terminator	Bus termination resistor
a		T-Cable 8-pin	900 mm/50 mm, Do not extend!
4	1951-00	Throttle Topmount	
22	000-00858	Gateway	
U		Gateway Power cable	1700 mm
b		Backbone TorqLink cable 8-pin	5000 mm
17		Emergency switch with cable	1000 mm
20		Key switch	
g		Cable for key switch 6-Pin to 8-pin	1000 mm
13	000-00876	TorqLink Terminator	Bus termination resistor
a		T-Cable 8-pin	900 mm/50 mm, Do not extend!
9	2206-20; 2206-30; 2206-40	Charger Power 24-3500	350 W
P		+ DC charge cable	2600 mm; Do not extend!
Q		- DC charge cable	2600 mm; Do not extend!
B+		+ Battery pole	
B-		- Battery pole	
AC		AC power cable	1500 mm

# Installation Drawing: I06

Version 1.0

Bill of material/Legend/Information



This installation drawing is an addition to the original operating instructions.  
Read operating instructions before wiring.



Pos.	Item number	Name	Remarks
Optional equipment			
10	2210-00	Fast Charger Power 24-3500	1700 W
P		+ DC charge cable	2400 mm; Do not extend!
Q		- DC charge cable	2400 mm; Do not extend!
B+		+ Battery pole	
B-		- Battery pole	
AC		AC power cable	2000 mm
11	2207-00	Solar charge controller Power 24-3500	
P		+ Charge cable	1000 mm
Q		- Charge cable	1000 mm
R		+ Input solar cable	1000 mm
S		- Input solar cable	1000 mm
12	2211-00	Fast solar charge controller Power 24-3500	
P		+ Charge cable	300 mm
P1		+ Charge cable	2200 mm
Q		- Charge cable	2500 mm
21		Fuse	100 A/58 V
R		+ Input solar cable	not included
S		- Input solar cable	not included

Connect the cruise motor and terminator to each end of the backbone.  
The TorqLink bus system requires a terminator (terminating resistor) at both ends of the backbone in order to function correctly.  
One of the terminators is located in the „Terminator Single“, „Terminator Twin“, „Throttle 1918-00“, „Throttle 1976-00“, the other is built into the cruise motor. Therefore, when installing, make sure that the components „Terminator“ and „Cruise motor“ are each connected to one end of the backbone.  
The connection position of the remaining components on the backbone can be freely selected.

Keep the following points in mind when planning:

- An earthing point is required for your Torqueedo system. Take into account the connection and the cables required for this in your planning. The required cable cross-sections can be found in the section Tools, equipment and material.
- First determine and plan the installation positions of all components.
- Measure the required length of the TorqLink backbone.
- Measure the lengths of all required stub lines (cable connection between component and TorqLink backbone).
- When planning, please note that TorqLink drop cables must not be extended. If necessary, plan the TorqLink backbone so that the components can be connected through the TorqLink drop cable without an extension. If necessary, extend the TorqLink backbone to connect a component that is far away; you can find corresponding extensions in our accessories catalogue.
- Cables must be fixed every 400 mm, plan attachment material. In places where fastening is not possible, a scuff guard must be fitted.
- Openly laid cables (e.g. inflatable boat) must be protected with chafing protection, plan sufficient material.
- When planning, please note not to bundle power cables with data or antenna cables (e.g. radios) for other loads.
- Observe the minimum bending radius of the cables when planning.
- If a second earthed onboard power system is available, ensure that both systems use a common earthing point.
- Live parts must be fitted or installed with protection against accidental contact; the necessary installation space must be taken into account during the planning stage.
- Always connect batteries as the last component to the system to avoid short circuits and voltage peaks.
- Do not extend drop cables, extend backbone if necessary.
- Protect plugs and contacts against contamination before installing them.
- Do not pull at the cables.
- Do not twist cables.
- Do not install cables in permanently wet areas such as bilges.
- Install cables free of chafing and not around sharp edges, if necessary, attach chafing protection.
- Maintain bending limits.
- Install plug connections free of tension and load.

Observe the minimum bending radius when laying all cables:

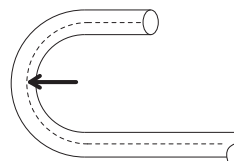

Torqueedo data cable	8 x diameter
Torqueedo power cable	8 x diameter
Earth cable	see cable manufacturer's specifications
Other power cables	see cable manufacturer's specifications

# Installation Drawing: I06

Version 1.0

Power cable connection



This installation drawing is an addition to the original operating instructions.  
Read operating instructions before wiring.

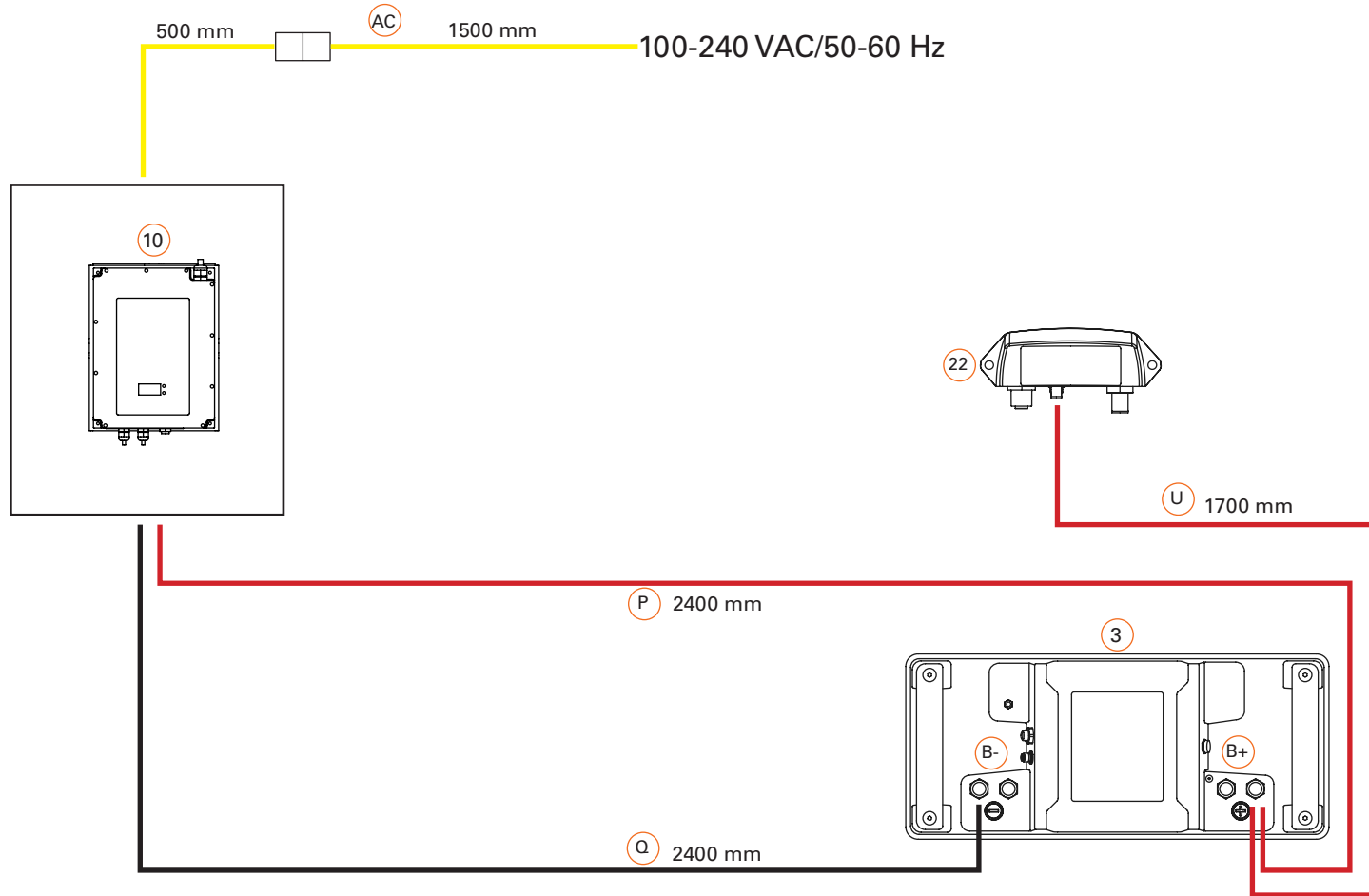

— Positive power cable  
— Negative power cable

— Positive charging cable  
— Negative charging cable

— AC power cable

Power cable connection

# Installation Drawing: I06

Version 1.0

Power cable connection



This installation drawing is an addition to the original operating instructions.  
Read operating instructions before wiring.

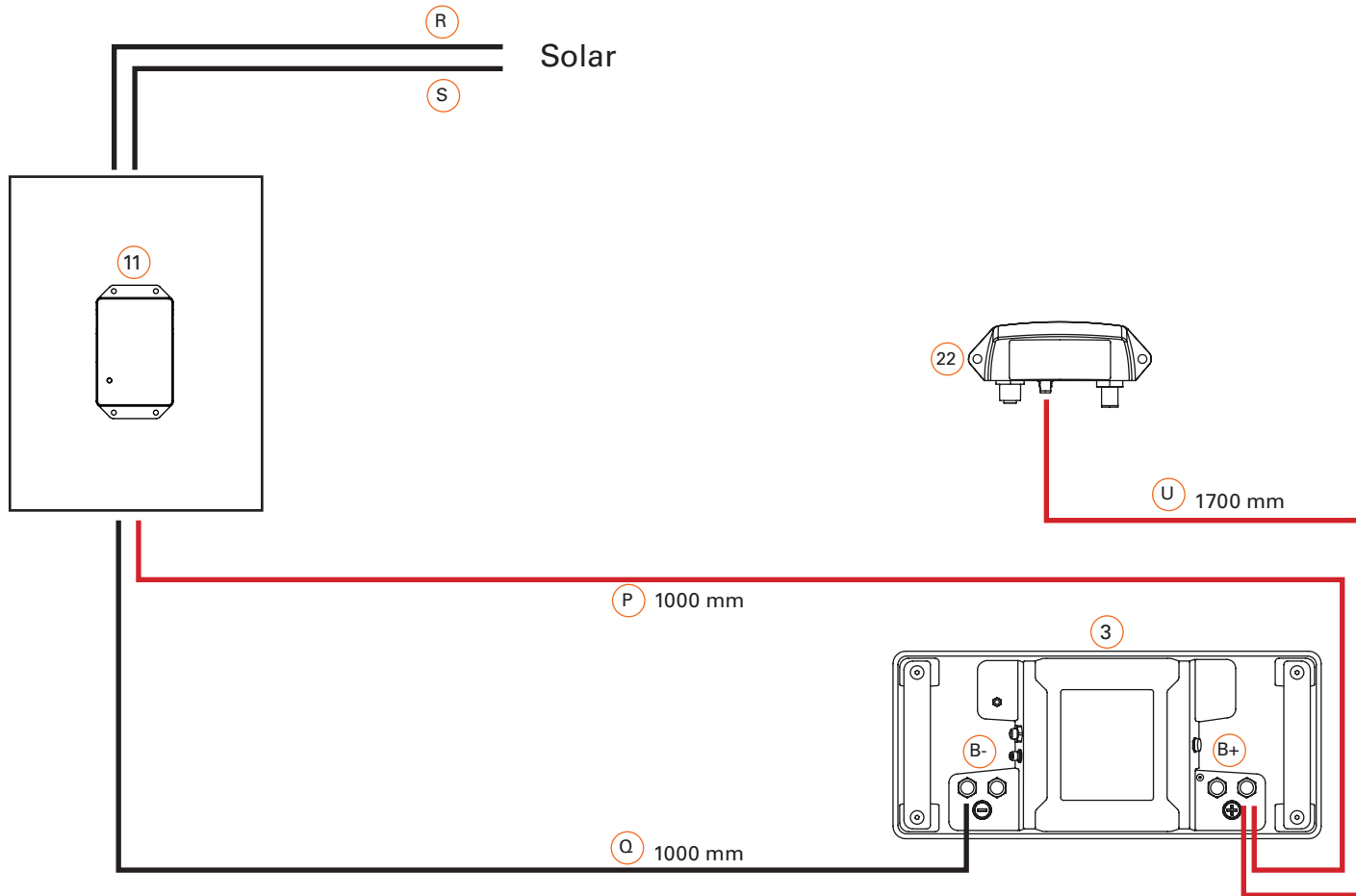

— Positive power cable  
— Negative power cable

— Positive charging cable  
— Negative charging cable

— AC power cable

Power cable connection



# Installation Drawing: I06

Version 1.0

Power cable connection



This installation drawing is an addition to the original operating instructions.  
Read operating instructions before wiring.

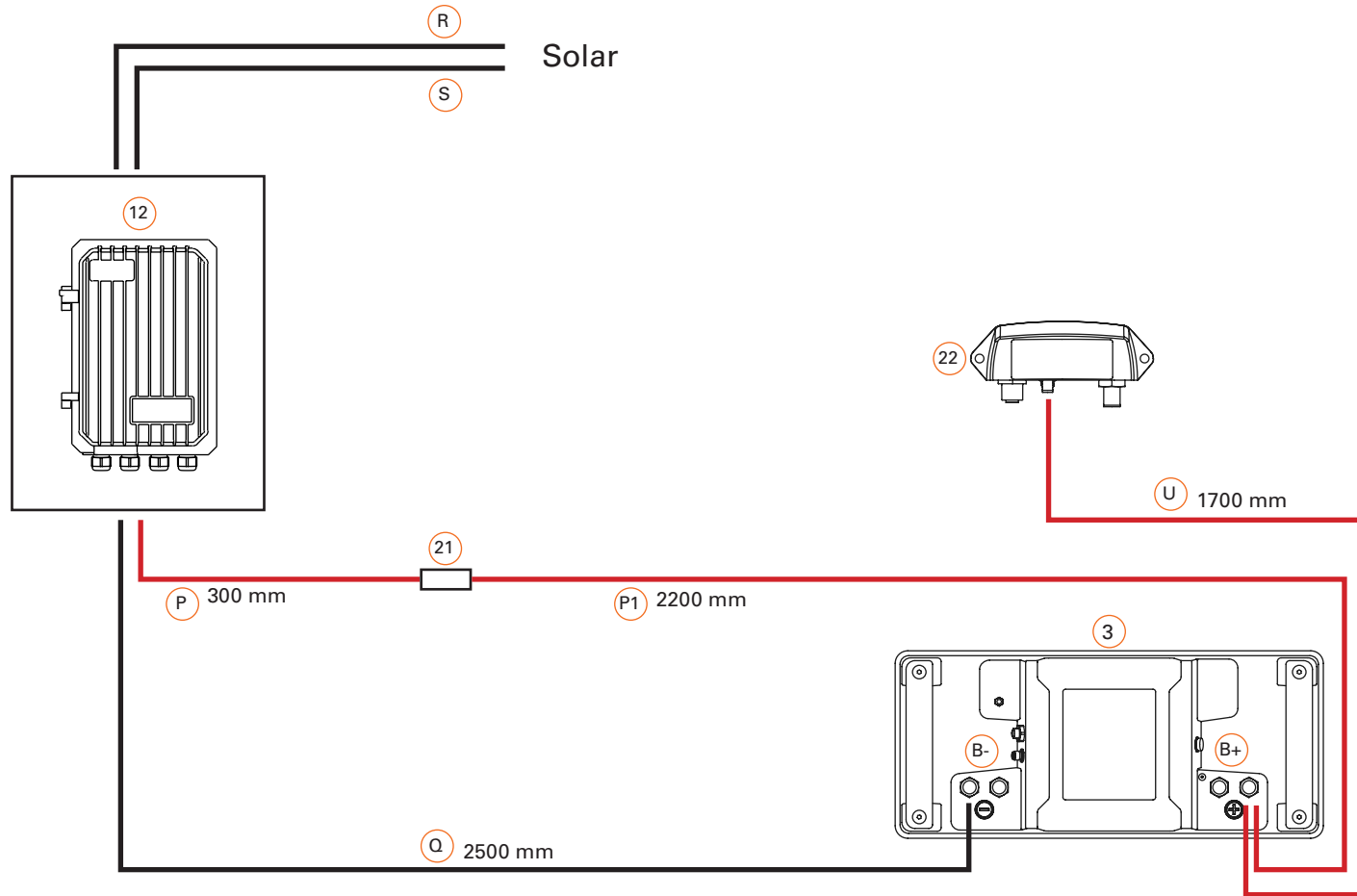

— Positive power cable  
— Negative power cable

— Positive charging cable  
— Negative charging cable

— AC power cable

Power cable connection